

NOTES: UNLESS OTHERWISE SPECIFIED

1. SEE DRAWING NO. CB-00288 AND PROCEDURE P-1000 FOR ASSEMBLY AND TEST INSTRUCTION. PROCEDURES AND ASSEMBLY DRAWING ARE FOR INTERNAL USE ONLY.
2. ALL TESTING IS PERFORMED IAW BATTERY COUNCIL INTERNATIONAL STANDARD.
3. ALL DIMENSIONS ARE IN INCHES [MM]
4. TERMINAL HARDWARE KIT PROVIDED, PART NUMBER 6923

REVISIONS			
REV	DESCRIPTION	DATE	APPROVED
A	CHANGED HANDLE DIRECTION	2/26/07	JBT
B	REVISED COVER & HANDLES	11/6/07	JBT
C	REVISED TERMINAL DAMS, TERMINAL HEIGHT & HANDLES	9/16/09	JBT

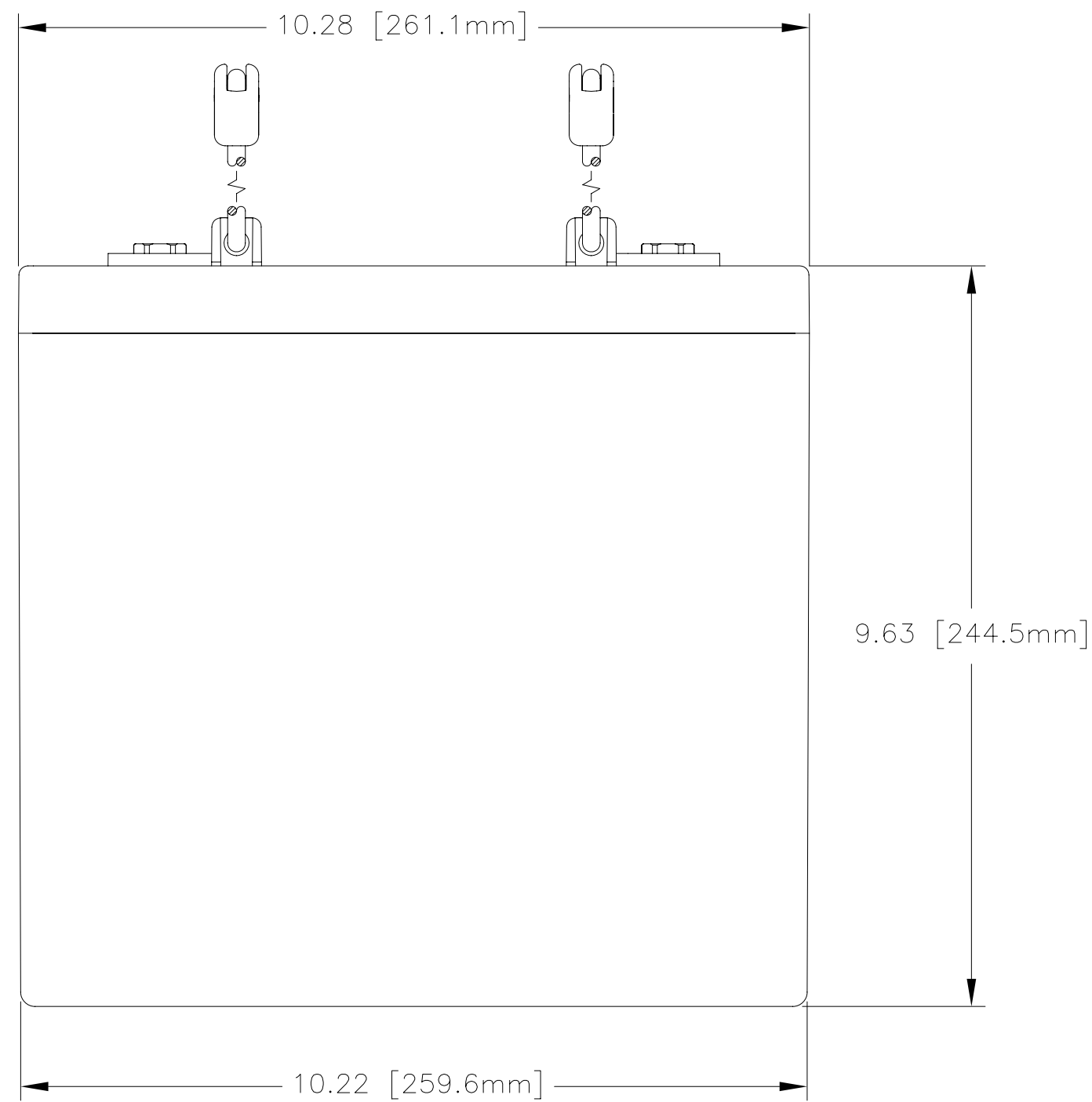
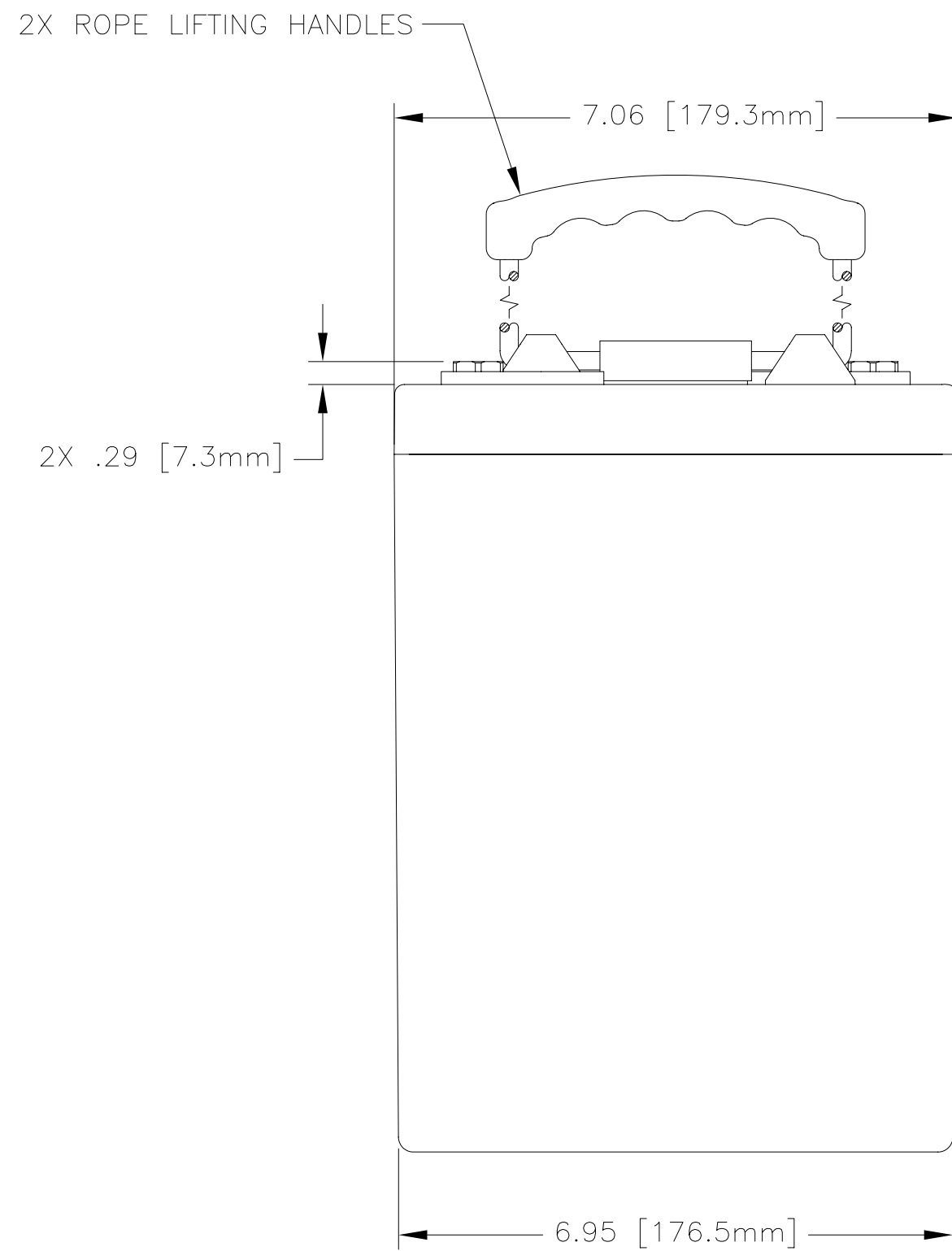
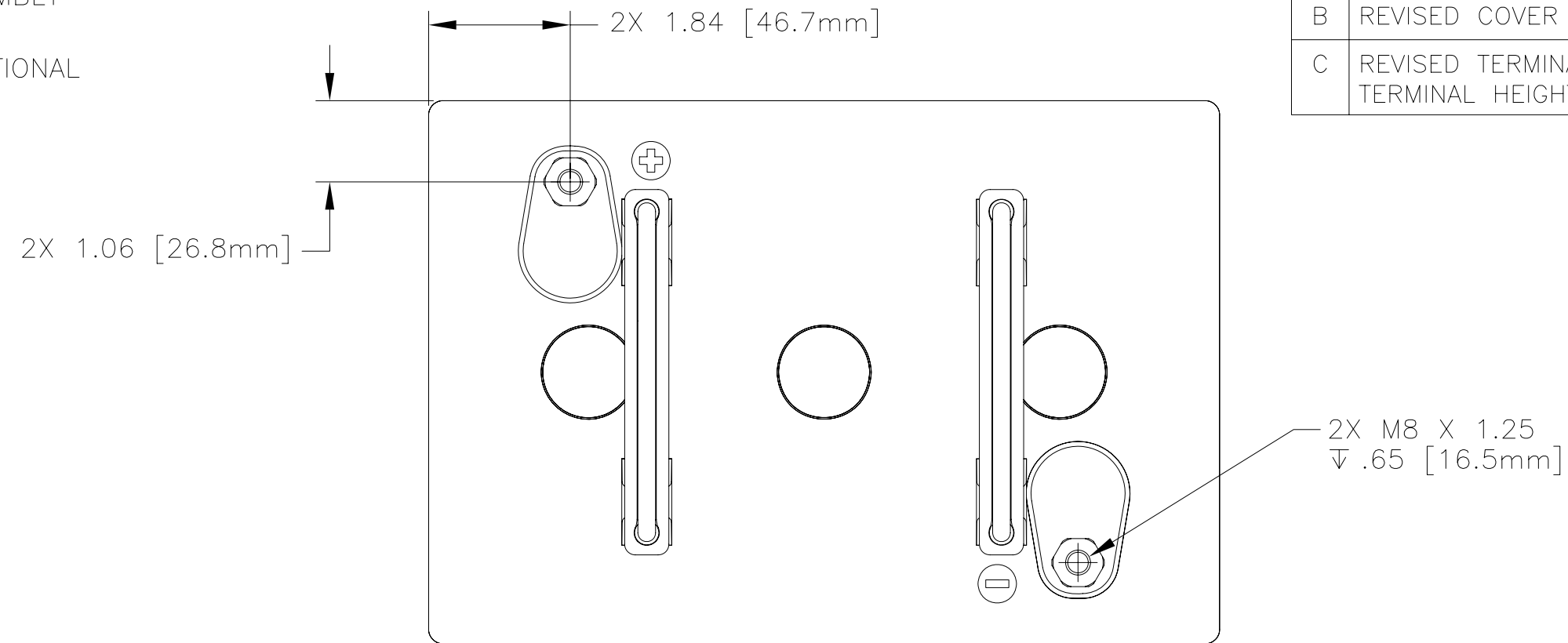

ENVELOPE DRAWING

CAPACITY RATINGS	
PART NUMBER	GPL-4CT
NOMINAL WEIGHT	66 LBS [30.0 KG]
AMPERE HOUR CAPACITY @ 20 HOUR 1.75 VOLTS/CELL @ 77°F (25° C)	220 AH
MINUTES OF DISCHARGE @ 25 AMPS 1.75 VOLTS/CELL @ 77°F (25° C)	492 MIN

QTY REQD	CAGE CODE	PART OR IDENTIFYING NO.	NOMENCLATURE OR DESCRIPTION	MATERIAL SPECIFICATION	ITEM NO.
PARTS LIST					
UNLESS OTHERWISE SPECIFIED DIMENSIONS ARE IN INCHES TOLERANCES ARE:			CONCORDE BATTERY CORPORATION 2009 SAN BERNARDINO RD, W. COVINA, CA 91790		
FRACTIONS DECIMALS ANGLES		APPROVALS		DATE	
± 1/32 .XX ± .12 ± 1°		DRAWN D AYALA		1/4/07	
.XXX ± .060		CHECKED AMIII		1/8/07	
TREATMENT NONE		APPROVED JBT		1/10/07	
FINISH NONE		ISSUED JJ		9/18/09	
SIMILAR TO N/A		ACT WT N/A		CALC WT N/A	
SIZE	CAGE CODE	DWG NO.	REV		
C	63017	GPL-4CT	C		
SCALE	1/2	SHEET		1 OF 1	